



Luxury Homes  
ARCHITECTURE & INTERIORS



SOFAS

SILLONES | ARMCHAIRS

POUFFS

MESAS | TABLES

SILLAS | CHAIRS

COMEDORES | DINING TABLES

MUEBLES | FURNITURE

DORMITORIOS | BEDROOMS

**ESPEJOS | MIRRORS**

ALMOHADILLAS | PILLOWS

EXTERIOR | OUTDOOR

ALMOHADILLAS | PILLOWS



4218/10 ESPEJO | MIRROR  
PAG. 308



4220/10 ESPEJO | MIRROR  
PAG. 309



4229 ESPEJO | MIRROR  
PAG. 310



5075 ESPEJO | MIRROR  
PAG. 311

# 4218/17

**4218/17** ESPEJO | MIRROR  
**1730** SILLA | CHAIR

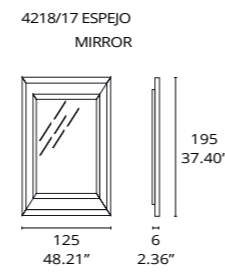

**Espejo 4218/17** tapizado en la tela Cool 1-3110-093 (S.7). Disponible con iluminación led. **Silla 1730** tapizada en la tela London C/867 (S.7) y patas lacadas en negro (F1).

**Mirror mod.4218/17** is upholstered in fabric Cool 1-3110-093 (S.7). Led light available. **Chair mod.1730** upholstered in fabric London C/867 (S.7) with black lacquered legs.

# 4220/10

**4220/10** ESPEJO | MIRROR

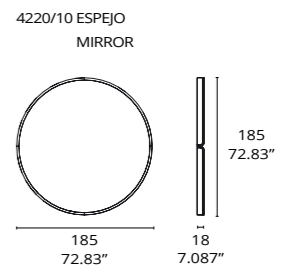

**Espejo 4220/10** tapizado en piel Camoscio C/36 (S.15) y Camoscio C/36 Quadrato F-09 (S.15). Espejo en gris.

**Mirror mod.4220/10** is upholstered in leather Camoscio C/36 (S.15) and Camoscio C/36 Quadrato F-09 (S.15) with grey mirror.

# 4229/10

4229/10 ESPEJO | MIRROR

4229/10 ESPEJO | MIRROR

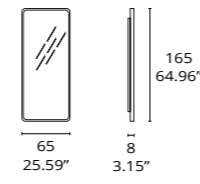

Espejo 4229 lacado en cobre brillo (F7) con espejo en gris.

Mirror mod. 4229 lacquered in glossy copper (F7) with grey glass.



# 5075

5075 ESPEJO | MIRROR

5075 ESPEJO  
MIRROR

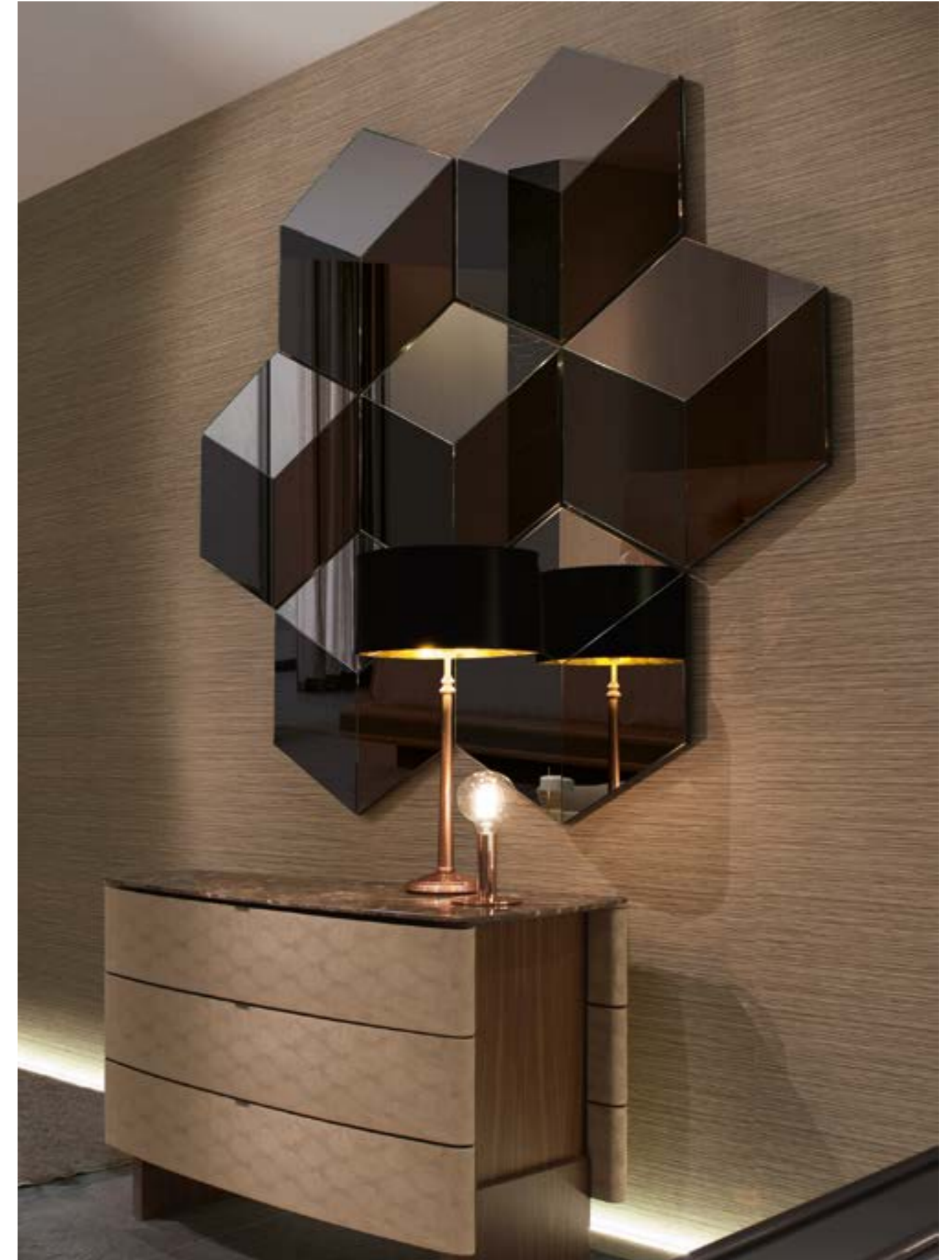
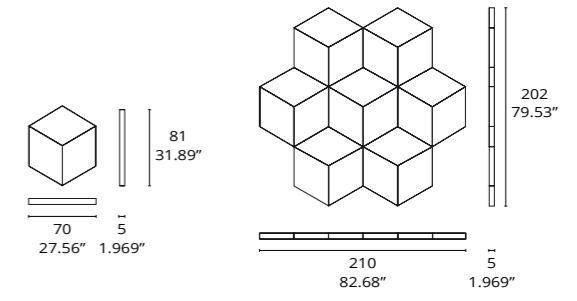

### Notas de interés

Lh Arquitectura y Tecni Nova, s.l.u. dota de protección jurídica a sus creaciones, a través de la adquisición de derechos de Propiedad Industrial mediante la inclusión de sus productos en el Registro de los Dibujos y Modelos Industriales regulados en el Estatuto sobre Propiedad Industrial RDL 26 Julio de 1929 y el la Ley 11/1986 de 20 de Marzo de Patentes. Este sistema le permite ejercer sus derechos exclusivos sobre la fabricación, comercialización y difusión gráfica de sus registros y entablar cuantas acciones judiciales estime oportunas en defensa y contra el plagio que sobre sus modelos pudiese realizar cualquier tercero.

La empresa se reserva el derecho de hacer cualquier modificación sobre sus modelos, siempre que sea para mejora de los mismos.

### Important notes

LH Arquitectura and Tecni Nova, s.l.u. provides judicial protection for its creations, through the acquisition of industrial property rights by means of the inclusion of this products in the Register of the desingns and industrial models regulated in the Statute on Industrial ownership Royal Decree Law, July 26, 1929 and Law 11/1986 dated March 20 of Patents. This system permits the exercising of exclusive rights of fabrication, commercialization and graphic dissemination of their records and to establish whatever judicial actions considered appropriate in defense of and against plagerism of their models that could be carried out by any third party.

The company reserves the right to make any modification to its mod els, on condition that this is in order to make improvements.



**Spain**

LH Arquitectura  
C/ El Abeto 11. 46900 Torrent (Monte Real)  
Valencia. Spain  
email: lh@lharquitectura.com  
phone: +34 960 061 914 - +34 656846700

**China**

16 Tiantaishan Road Wenzhou City  
Zhejiang Province, China, 3250000

